

C-HRV 366-S

High performance, long life and low maintenance

Description

The C-HRV 366-S high performance counterflow heat exchanger is our most popular heat exchanger. Maximum efficiency with minimum pressure drop due to our unique and patented channel design. The C-HRV 366-S offers the highest quality, long life and low maintenance.



Product benefits

- Cleanable, hygienic, mold and bacteria resistant
- Standard: Condensation drain holes
- Options: Rib, fire protection grid
- Available heights: 90 – 500 mm (in 5 mm steps)
- Leakage: < 1% of nominal flow rate, 100% leakage tested
- Material resistance: -20 °C – +50 °C

Product dimensions (mm)

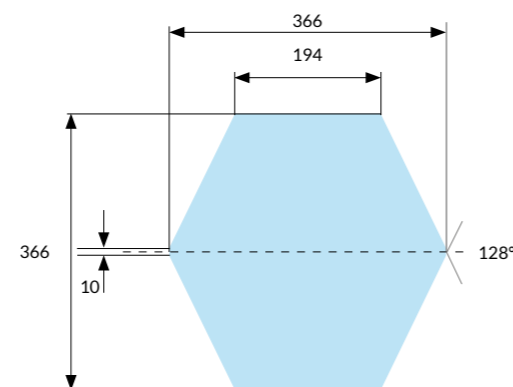

Temperature efficiency

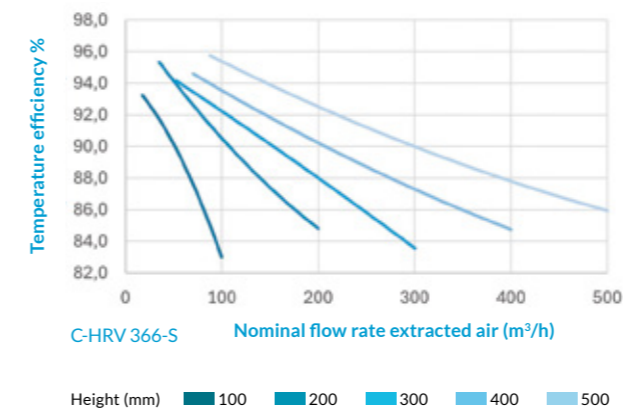

Pressure drop

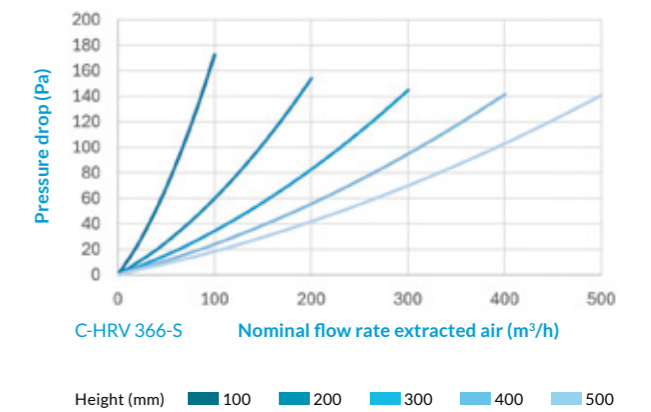

Based on test conditions following NEN-EN 308:2022 (intake air: temp. 5 °C, humidity 70 %; extracted air: 25 °C, humidity 25 %) Calculate your specific conditions with our CORE Online Calculator.

Standards

- Hygiene Standard
 - VDI6022 sheet 1 (01/2018)
 - ÖNORM H6021 (01/2023)
 - SWKI VA104-01 (01/2019)
- Fire Standard
 - EN DIN13501-1 (Class E)
 - ISO 11925 (Class E)
- Quality Management
 - DIN ISO 9001: 2015

Weights (kg)

Typ	kg
HRV366-H100-S	1,73
HRV366-H200-S	3,01
HRV366-H300-S	4,32
HRV366-H400-S	5,63
HRV366-H500-S	6,95