

CORE C-HRV 369

DESCRIPTION

High performing Counterflow Heat Exchanger with maximum efficiency due to our unique and patented channel design. The C-HRV 369 is characterized by the highest quality, a long life and low maintenance and can be custom made to fit your specific needs.

TEMPERATURE EFFICIENCY

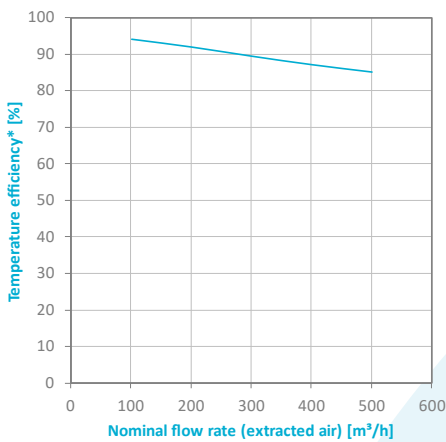

*Based on a CORE height of 500 mm, test conditions following DIN EN 308:1997-06 (intake air: temp. 5 °C, humidity 70 %; extracted air: 25 °C, humidity 50 %)

PRODUCT BENEFITS

- Water washable and hygienic
- Available heights: 90 – 500 mm (in 5mm steps)
- Leakage: < 1 % of nominal flow rate, 100 % leakage tested
- Material resistance: -20 °C – +50 °C

PRESSURE DROP

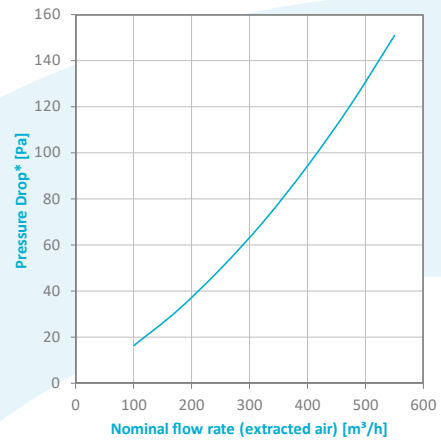

DIMENSIONS [mm]

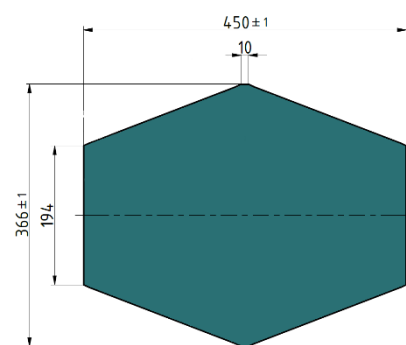

Visit us at www.core.life to learn more about us and our products. We look forward to hearing from you!