

CORE C-HRV 366-L

DESCRIPTION

High performing Counterflow Heat Exchanger with maximum efficiency and less pressure drop due to our adapted unique and patented channel design.

The C-HRV 366-L is characterized by the highest quality, a long life and low maintenance and can be custom made to fit your specific needs.

PRODUCT BENEFITS

- Water washable and hygienic
- Available heights: 90 – 500 mm (in 5mm steps)
- Leakage: < 1 % of nominal flow rate, 100 % leakage tested
- Material resistance: -20 °C – +50 °C

TEMPERATURE EFFICIENCY

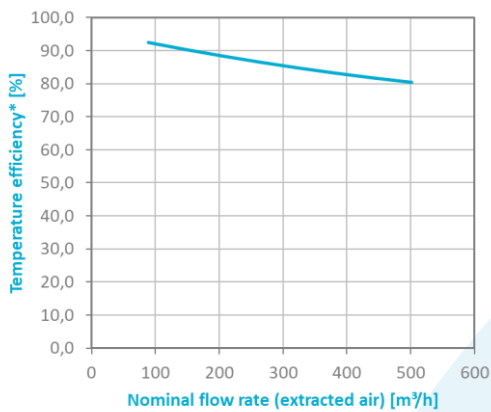

PRESSURE DROP

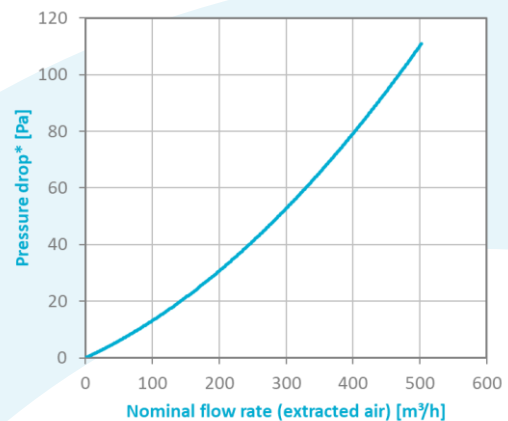

*Based on a CORE height of 500 mm, test conditions following DIN EN 308:1997-06 (intake air: temp. 5 °C, humidity 70 %; extracted air: 25 °C, humidity 50 %)

TEMPERATURE EFFICIENCY (HEIGHTS 100 – 400 mm)

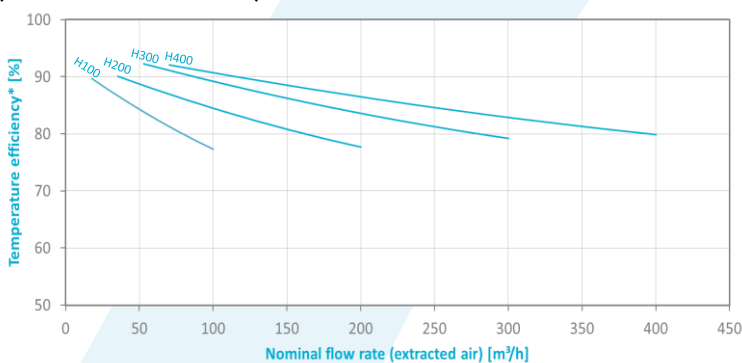

*Test conditions following DIN EN 308:1997-06 (intake air: temp. 5 °C, humidity 70 %; extracted air: temp. 25 °C, humidity 50 %).

DIMENSIONS [mm]

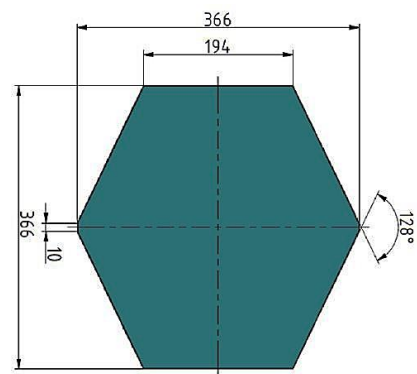

Visit us at www.core.life to learn more about us and our products. We look forward to hearing from you!