

## CORE C-HRV 195

### DESCRIPTION

High performing Counterflow Heat Exchanger with maximum efficiency due to our unique and patented channel design. The C-HRV195 is characterized by the highest quality, a long life and low maintenance and can be custom made to fit your specific needs.

### PRODUCT BENEFITS

- Water washable and hygienic
- Available heights: 50 – 300 mm
- Leakage: < 1 % of nominal flow rate, 100 % leakage tested
- Material resistance: -20 °C – +60 °C

### TEMPERAURE EFFICIENCY

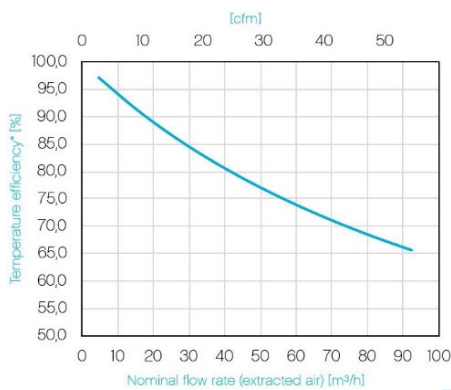

\*Based on a CORE height of 300 mm, test conditions following DIN EN 308:1997-06 (intake air: temp. 5 °C, humidity 70 %; extracted air: 25 °C, humidity 50 %)

### PRESSURE DROP

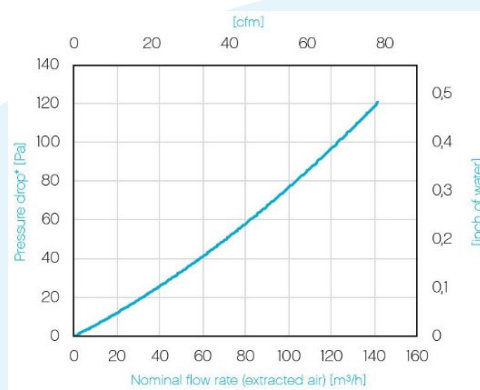

### DIMENSION [mm]

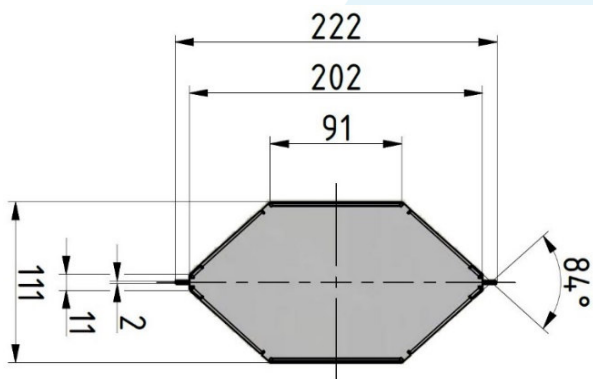

Visit us at [www.core.life](http://www.core.life) to learn more about us and our products. We look forward to hearing from you!