

CORE C-ERV 366

DESCRIPTION

High performing Counterflow Enthalpy Exchanger with maximum efficiency due to our unique and patented channel design. Its special membrane allows the transfer of humidity. Therefore, humidity levels can be controlled, and the living comfort improved. The C-ERV366 is characterized by the highest quality, a long life and low maintenance and can be custom made to fit your specific needs.

PRODUCT BENEFITS

- Virtually no condensation forms inside the CORE, reducing the need for a condensate drain, lowering the instances where freezing occurs and thus providing better overall efficiency levels when compared to HRVs
- Manufactured with a hygienic, mold and bacteria resistant, water washable polymer membrane
- Available heights: 90 – 500 mm
- Leakage: < 1 % of nominal flow rate, 100 % leakage tested
- Material resistance: -20 °C – +50 °C (very low freezing point)

EFFICIENCY

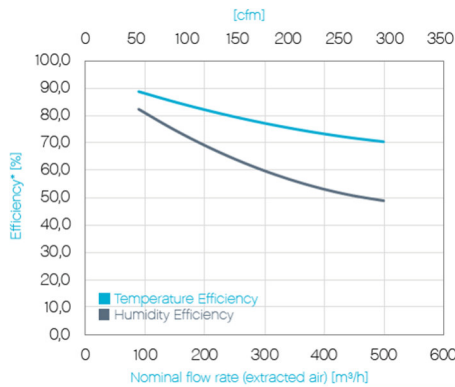

PRESSURE DROP

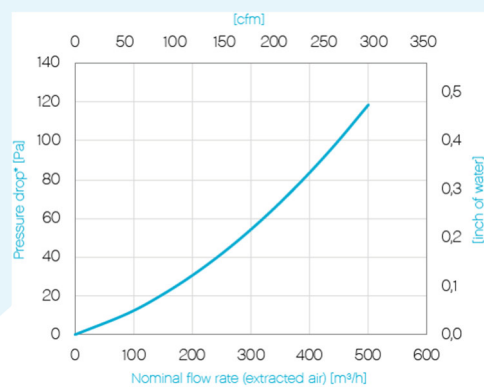

*Based on a CORE height of 500 mm, test conditions following DIN EN 308:1997-06 (intake air: temp. 5 °C, humidity 70 %; extracted air: 25 °C, humidity 50 %)

TEMPERATURE AND HUMIDITY EFFICIENCY (HIGHTS 150 – 400 mm)

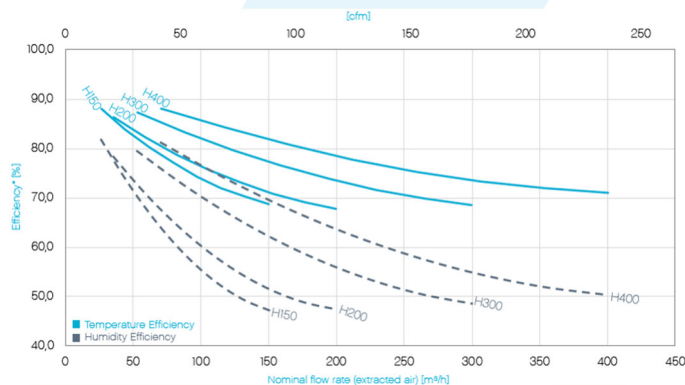

*Test conditions following DIN EN 308:1997-06 (intake air: temp. 5 °C, humidity 70 %; extracted air: temp. 25 °C, humidity 50 %).

DIMENSIONS [mm]

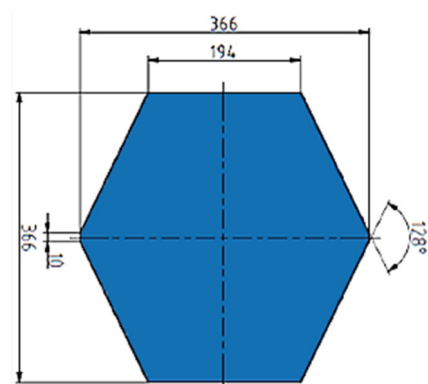

Visit us at www.core.life to learn more about us and our products. We look forward to hearing from you!